

© 2006 Mazda Motor of America, Inc.

Subject: FRONT BUMPER REINFORCEMENT RIB - SERVICE TIP	Bulletin No: 09-004/06
	Last Issued: 1/31/2006

APPLICABLE MODEL(S)/VINS

2006 Mazda5

DESCRIPTION

On replacement front bumper covers for 2006 Mazda5 vehicle, a reinforcement rib is manufactured into the bumper cover at the radiator grille opening. The purpose of this reinforcement rib is to prevent deformation during storage and transportation.

This service tip is being provided to outline proper removal of this reinforcement tab.

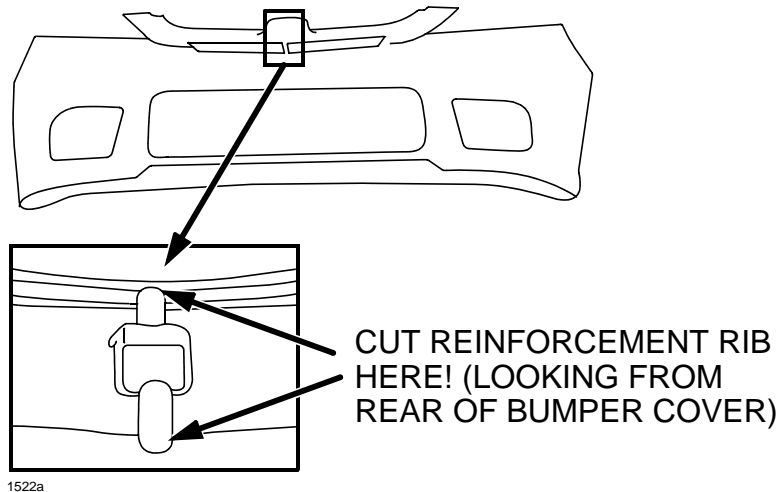

REPAIR PROCEDURE

When preparing and installing a new front bumper cover (CC53-50-031C AA) to a vehicle, paint the bumper cover first, then remove the reinforcement rib. If the reinforcement rib is not removed from the bumper cover, the radiator grille will not be able to be installed.